

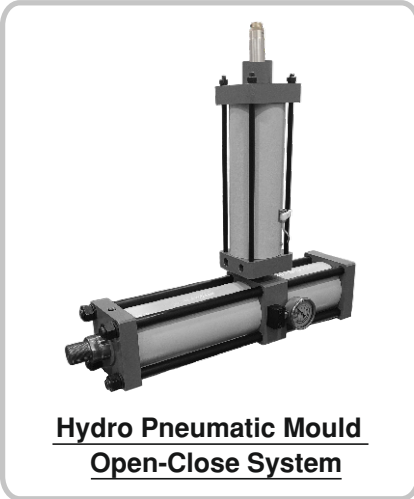

Typical Automatic Stretch Blow Moulding Machine for 'PET' Bottles



Hydro Pneumatic Mould Open-Close System



Neck Sealing Cylinder with Hollow Shaft



T & TM Series Cylinder

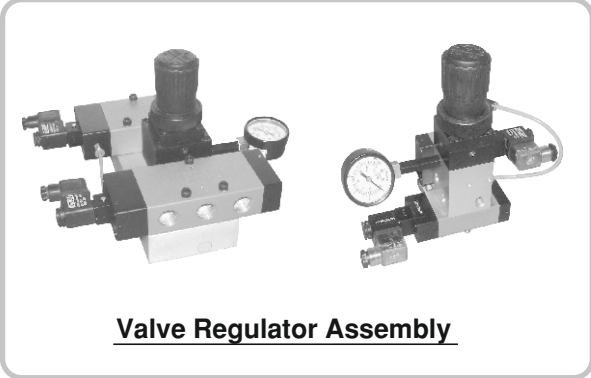

Valve Regulator Assembly



Cushion (Deceleration) Solenoid Valves



Single & Dual Blow Solenoid Valves

1. General Description

- 1.1 The general layout of major pneumatic components used in stretch blow moulding machines is given in **Fig 1**.

“**MERCURY**” Series “**XA**” Hydro Pneumatic Clamping Systems use low cost pneumatic elements to achieve the large forces associated with pure hydraulic systems, with 50% saving in energy and 100% increase in speed over an equivalent hydraulic system.

The system has three stages of operation :-

- (a) Initial Low force, Large travel, Rapid Approach.
- (b) High Force, Short travel (typically 3mm), Power Stroke.
- (c) Low Force, Rapid Retraction.

The selection of the correct system is very important for efficient performance. General guidelines is given in the appropriate sections. Please feel free to contact us for further guidance if required.

1.2 Sequence of Operation

- (a) The heated perform is placed in the mould and the machine cycle is initiated by pressing 2 Hand Safety Push Buttons.
- (b) The Series “**XA**” Clamp Cylinder closes the mould at High Speed with a low force (hence low compressed air consumption).
- (c) Just 3 to 5mm before the two halves of the mould touch, the **Cushion Solenoid Valve** is switched “**ON**”. This Cushions the closing of the mould and avoids banging and machine vibration. The rate of deceleration can be varied by adjusting screw on **Cushion Solenoid Valve**.
- (d) After the mould closes completely the **Power Stroke Solenoid Valve** of Series “**XA**” Cylinder is switched “**ON**” which causes the clamping pressure to increase to the required tonnage. The mould is now held in the closed position by a very large force
- (e) The **Neck Sealing Cylinder** now moves down and seals the neck and **Stretch Pin Cylinder** extends to stretch the preform to the desired length.
- (f) The low pressure solenoid of **Dual Pressure Blow Solenoid Valve** is switched “**ON**”, causing initial stretch and blow at low force. After a delay the high pressure solenoid of a **Dual Pressure Blow Solenoid Valve** is switch “**ON**” for final blow and forming.
- (g) After the set blow time, the air exhausts, and all cylinders retract rapidly.

NOTE :- The ideal cycle time is 5 to 7 seconds. This can be achieved by proper selection and location of valves and pipe fittings and tubing. Please feel free to contact us with your machine details to enable us to guide you correctly.

General Layout of Pneumatic System for Stretch Blow Moulding

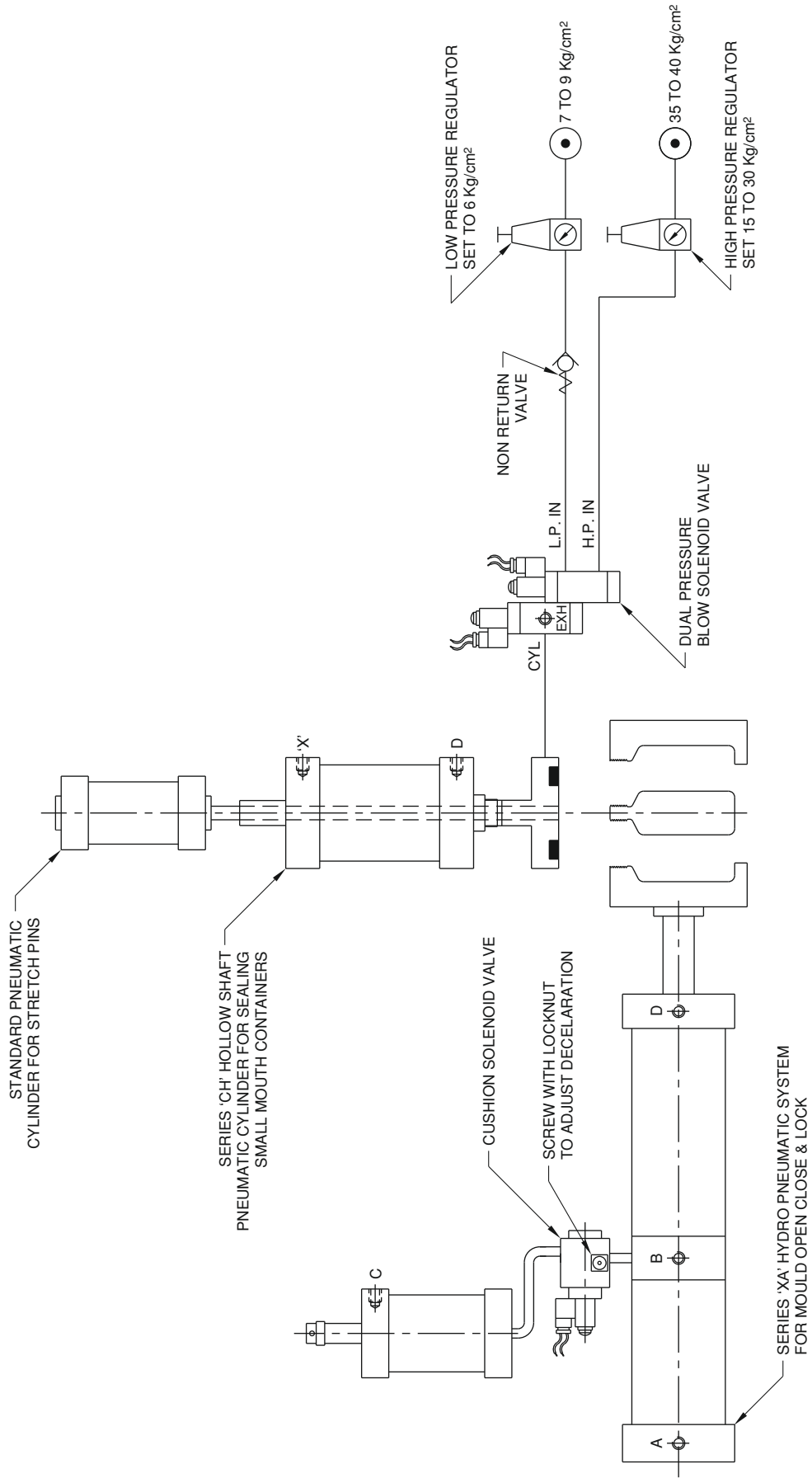

FIG. 1

Piping Layout (Series 'XA')

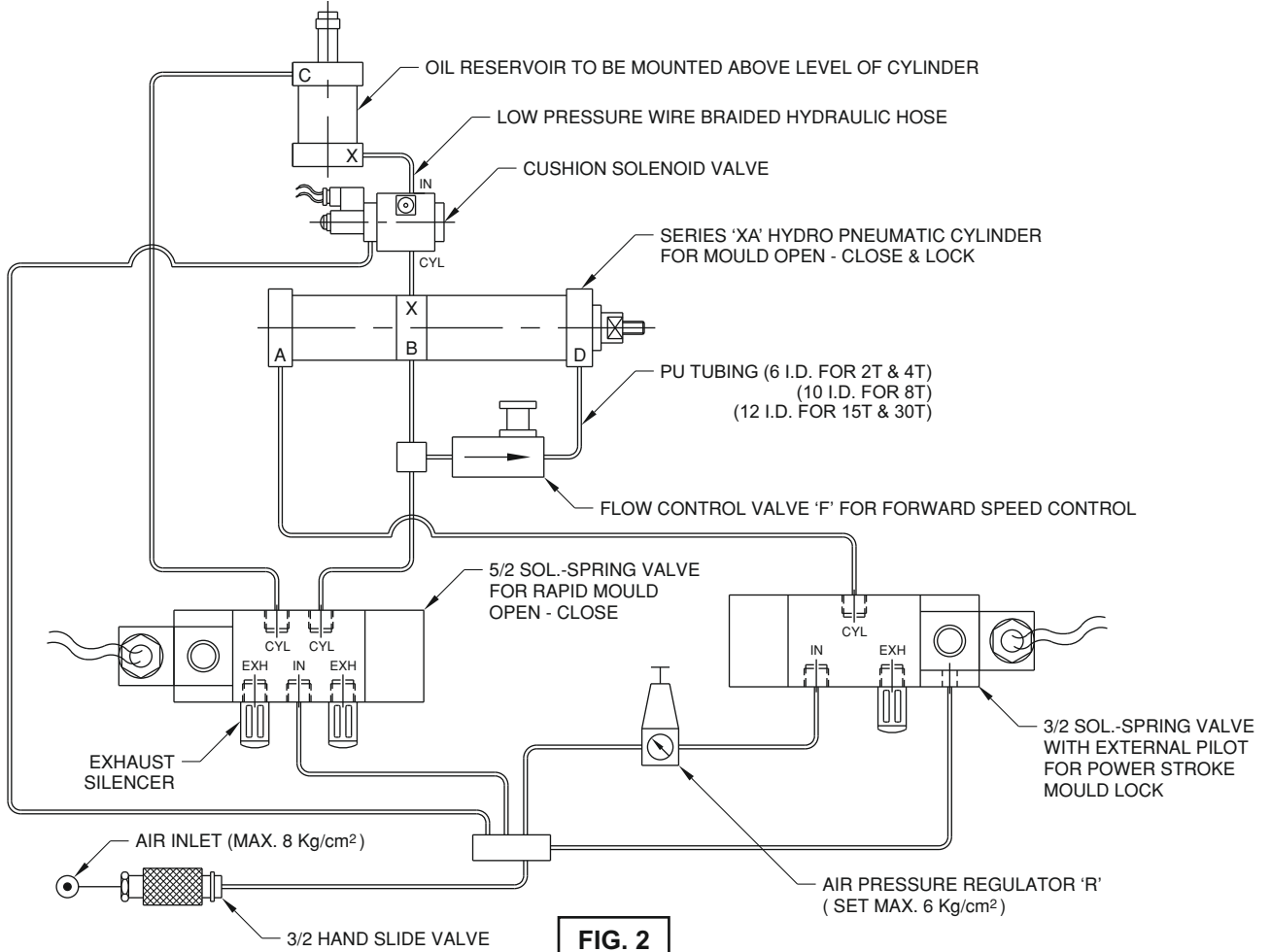

FIG. 2

Pneumatic Circuit Diagram (Series 'XA')

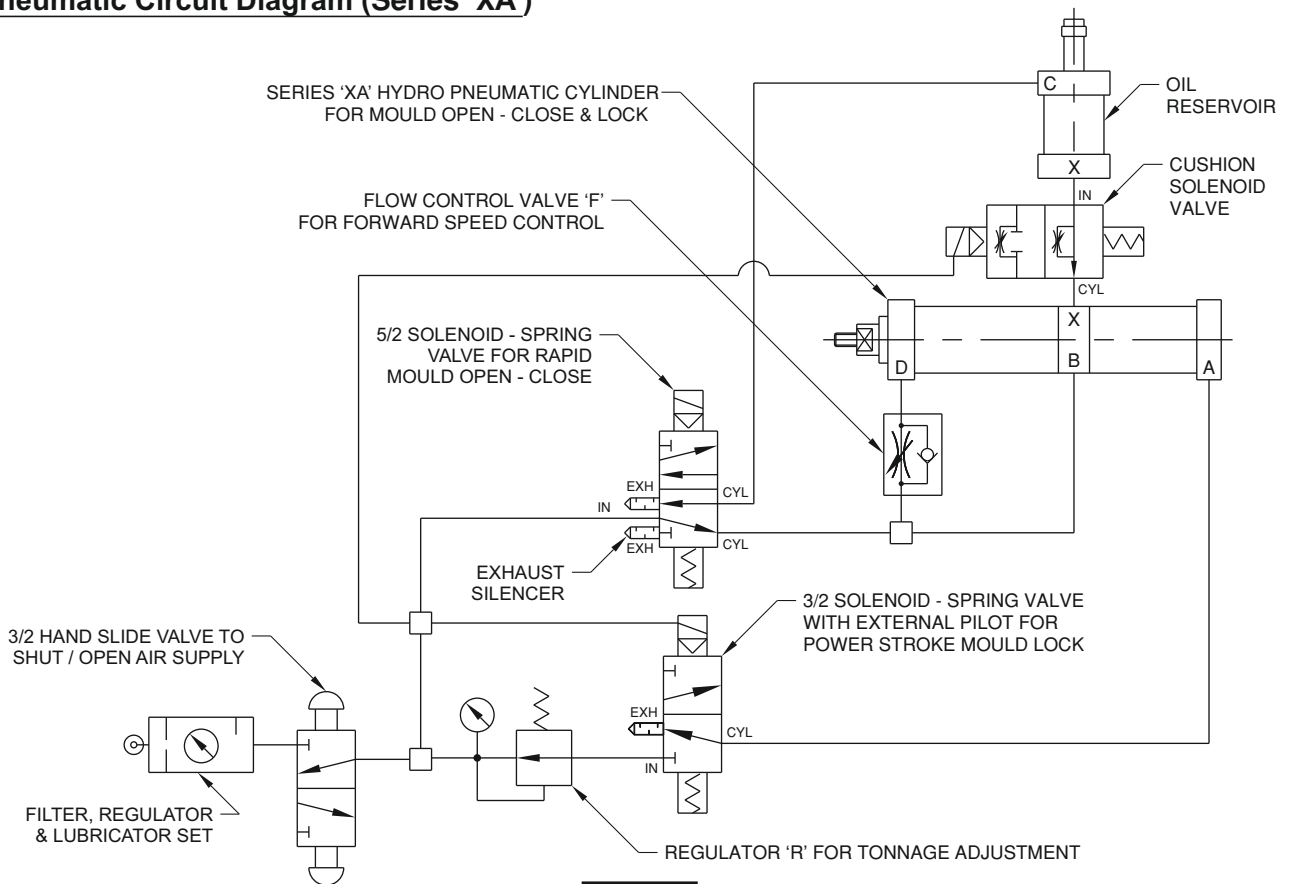

FIG. 3

2. Series “XA” Hydro Pneumatic Press System

The **Series “XA”** System has been developed for applications where the cylinder has to be mounted horizontally.

Refer to **Fig. 2** for Piping Layout, **Fig. 3** for Pneumatic Circuit and **Fig. 4** for overall dimensions and **Fig. 5** for cut section details and spare parts list.

The system consists of a Hydraulic Cylinder and an Air to Oil Intensifier unit assembled as an integral unit. The Oil Reservoir is mounted vertically and coupled to the hydraulic cylinder through a suitable low pressure hydraulic hose. Alternatively, to achieve high speed and less heating of oil, the reservoir can be mounted vertically and Port “X” through a suitable connector.

An optional **Cushion Solenoid Valve** can be fitted in the oil line between the Reservoir and the Hydraulic Cylinder Port “X” to decelerate and close the moulds without jerks and vibration.

2.1 Sequence of Operation

- (a) When the **Approach Solenoid Valve** is switched “**ON**”, air is admitted to Port ‘A’ and exhausted from ‘B’ and port ‘D’. The Output Shaft extends rapidly, with a low force, due to air pressure acting on reservoir piston through port ‘C’.
- (b) When the two halves of the mould are about to close, the **Cushion Solenoid Valve** is switched “**ON**”. This cause the main oil flow from Reservoir to the Hydraulic Cylinder to shut and the oil is made to flow slowly through an adjustable Flow Control Valve incorporated in the **Cushion Solenoid Valve**. The Cylinder movement is thus decelerated and the mould closes slowly without a bang.
- (c) When the moulds close fully, the **Power Stroke Solenoid Valve** is switched “**ON**”. This causes regulated air to be admitted to port ‘A’. The Intensifier Piston now moves forward and oil pressure in the Hydraulic Cylinder is increased by approximately 25 times the regulated air pressure. This high pressure oil now acts on the large diameter Hydraulic Cylinder to give the large clamping force. The clamping force can be varied by adjusting **Air Pressure Regulated ‘R’**.
- (d) After the machine cycle is over all the Solenoid Valves are switched “**OFF**”, causing air to be admitted to Port ‘B’ and Port ‘D’ and exhausted from port ‘A’ and port ‘C’. The Cylinder retracts rapidly.
- (e) To avoid vibration during mould opening, the **Cushion Solenoid Valve** can be switched “**ON**” just before the mould opens fully.

Series 'XA' Hydro Pneumatic Press Cylinder : Basic Dimensions

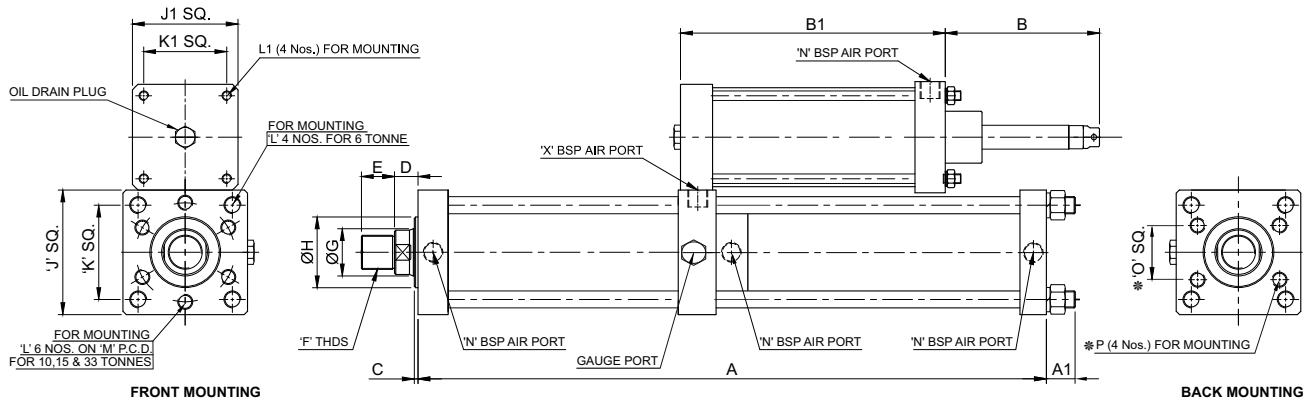

MODEL NO.	TON	TOTAL STROKE	POWER STROKE	A	A1	B	B1	C	D	E	F	ØG	ØH	J SQ.	J1 SQ.	K SQ.	K1 SQ.	L	L1	M	N	Ø' SQ.	*P	X
XA060-100	6	100	3	434	23	195	241	4	22	35	M24 x 2.0	32	55	105	95	78	70.5	M16 x 2.0	M10 x 1.5	-	1/4"	55	M10 x 1.5	3/4"
XA060-150	6	150	3	484	23	255	301	4	22	35	M24 x 2.0	32	55	105	95	78	70.5	M16 x 2.0	M10 x 1.5	-	1/4"	55	M10 x 1.5	3/4"
XA060-200	6	200	3	534	23	315	361	4	22	35	M24 x 2.0	32	55	105	95	78	70.5	M16 x 2.0	M10 x 1.5	-	1/4"	55	M10 x 1.5	3/4"
XA060-250	6	250	3	584	23	375	421	4	22	35	M24 x 2.0	32	55	105	95	78	70.5	M16 x 2.0	M10 x 1.5	-	1/4"	55	M10 x 1.5	3/4"
XA060-300	6	300	3	634	23	435	481	4	22	35	M24 x 2.0	32	55	105	95	78	70.5	M16 x 2.0	M10 x 1.5	-	1/4"	55	M10 x 1.5	3/4"
XA100-150	10	150	3	502	31	235	288	4	25	35	M36 x 2.0	50	75	132	112	-	88	M16 x 2.0	M10 x 1.5	105	1/2"	60	M12 x 1.75	3/4"
XA100-200	10	200	3	552	31	295	348	4	25	35	M36 x 2.0	50	75	132	112	-	88	M16 x 2.0	M10 x 1.5	105	1/2"	60	M12 x 1.75	3/4"
XA100-250	10	250	3	602	31	355	408	4	25	35	M36 x 2.0	50	75	132	112	-	88	M16 x 2.0	M10 x 1.5	105	1/2"	60	M12 x 1.75	3/4"
XA100-300	10	300	3	652	31	415	468	4	25	35	M36 x 2.0	50	75	132	112	-	88	M16 x 2.0	M10 x 1.5	105	1/2"	60	M12 x 1.75	3/4"
XA150-150	15	150	3	530	36	297	365	4	24.5	35	M40 x 2.0	63	90	170	140	-	106	M20 x 2.5	M12 x 1.75	125	1/2"	100	M16 x 2.0	1"
XA150-200	15	200	3	580	36	372	440	4	24.5	35	M40 x 2.0	63	90	170	140	-	106	M20 x 2.5	M12 x 1.75	125	1/2"	100	M16 x 2.0	1"
XA150-250	15	250	3	630	36	447	515	4	24.5	35	M40 x 2.0	63	90	170	140	-	106	M20 x 2.5	M12 x 1.75	125	1/2"	100	M16 x 2.0	1"
XA150-300	15	300	3	680	36	522	590	4	24.5	35	M40 x 2.0	63	90	170	140	-	106	M20 x 2.5	M12 x 1.75	125	1/2"	100	M16 x 2.0	1"
XA330-200	33	200	3	658	44	270	403	4	26	40	M48 x 3.0	63	75	220	178.5	-	140	M30 x 3.5	M16 x 2.0	135	1/2"	100	M16 x 2.0	1"
XA330-250	33	250	3	708	44	330	463	4	26	40	M48 x 3.0	63	75	220	178.5	-	140	M30 x 3.5	M16 x 2.0	135	1/2"	100	M16 x 2.0	1"
XA330-300	33	300	3	758	44	390	523	4	26	40	M48 x 3.0	63	75	220	178.5	-	140	M30 x 3.5	M16 x 2.0	135	1/2"	100	M16 x 2.0	1"

*NOTE : 'Ø' SQ. & 'P' Only For Back Mounting (BM) type Cylinder

FIG. 4

Flexible Coupling

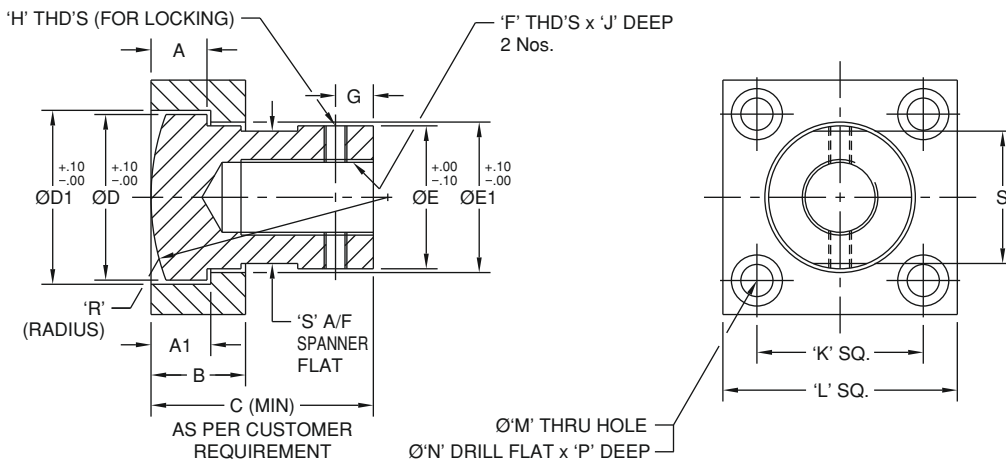

TON	A	A1	B	C	D	D1	E	E1	F	G	H	J	K	L	M	N	P	R	S
6	14.8	15	30	71	57.8	58	44.8	45	M24x2	10	M6x1	40	52	75	8.5	13.5	15	275	42
10	14.8	15	30	78	63.8	64	49.8	50	M36x2	10	M6x1	40	58	78	10.5	16.5	15	375	46
19	14.8	15	30	98	77.8	78	64.8	65	M40x2	15	M8x1.25	40	72	98	12.5	19	15	600	60
33	19.8	20	40	134	87.8	88	74.8	75	M48x3	15	M8x1.25	45	80	105	12.5	19	15	775	70

FIG. 5



'CH' Series High Pressure Cylinder

For Pet Blow Moulding Machines



Mechanical Characteristic

Barrel	: Aluminium
Piston Rod	: Carbon Steel
End Cover & Piston	: Aluminium
Seal	: Nitrile Rubber / XNBR
Bore	: Ø50, Ø63, Ø80, Ø100 & Ø125mm

Operating Conditions

Media	: Air (filtered 40µ & lubricated)
Temperature Range	: +5° to +50°C
Pressure Range	: 1 to 20 bar
Leakage	: Bubble Tight



CH CYLINDERS DIMENSIONAL DETAILS :

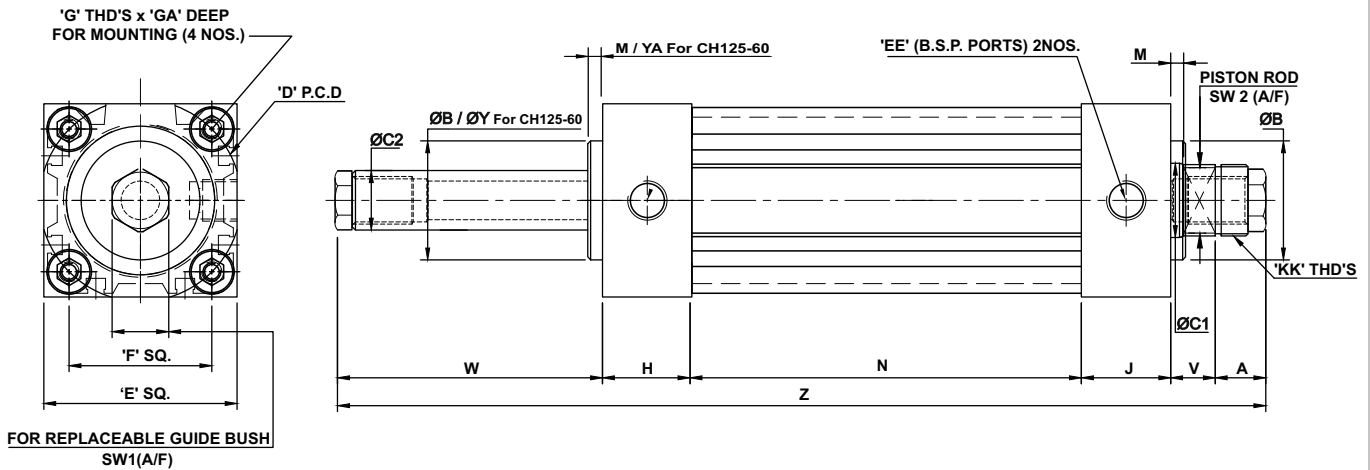

MODEL No.	PISTON Ø (mm)	A	ØB	ØC1	ØC2	D (P.C.D.)	E SQ.	EE (B.S.P.)	F SQ.	G	GA	H	J	KK	M	N	SW1	SW2	V	W	ØY	YA	Z
CH50-25(XX)HP	50	16	40	25	20	68.00	65	1/4"	48	M6	17	30	30	M24x1.5	5	81	19	22	16	38	-	-	211
CH50-50(XX)HP	50	16	40	25	20	68.00	65	1/4"	48	M6	17	30	30	M24x1.5	5	106	19	22	16	63	-	-	261
CH50-150(XX)HP	50	16	40	25	20	68.00	65	1/4"	48	M6	17	30	30	M24x1.5	5	206	19	22	16	163	-	-	461
CHN63-25(XX)HP	63	16	40	25	20	79.90	76	1/4"	56.5	M6	17	30	26	M24x1.5	4	81	19	22	20	38	-	-	211
CHN63-50(XX)HP	63	16	40	25	20	79.90	76	1/4"	56.5	M6	17	30	26	M24x1.5	4	106	19	22	20	63	-	-	261
CHN63-100(XX)HP	63	16	40	25	20	79.90	76	1/4"	56.5	M6	17	30	26	M24x1.5	4	156	19	22	20	113	-	-	361
CHN63-115(XX)HP	63	16	40	25	20	79.90	76	1/4"	56.5	M6	17	30	26	M24x1.5	4	171	19	22	20	128	-	-	391
CHN63-150(XX)HP	63	16	40	25	20	79.90	76	1/4"	56.5	M6	17	30	26	M24x1.5	4	206	19	22	20	163	-	-	461
CH80-50(XX)HP	80	16	48	32	25	100.00	98	1/4"	70.7	M8	15	30	29	M27x2.0	4	112.5	22	28	16	64.00	-	-	267.5
CH80-115(XX)HP	80	16	48	32	25	100.00	98	1/4"	70.7	M8	15	30	29	M27x2.0	4	177.5	22	28	16	129.0	-	-	397.5
CH80-150(XX)HP	80	16	48	32	25	100.00	98	1/4"	70.7	M8	15	30	29	M27x2.0	4	212.5	22	28	16	164.0	-	-	467.5
CH100-25(XX)HP	100	16	48	32	25	132.00	118	1/4"	93.3	M8	15	30	28	M27x2.0	2	87.8	22	28	17	38.7	-	-	217.5
CH100-50(XX)HP	100	16	48	32	25	132.00	118	1/4"	93.3	M8	15	30	28	M27x2.0	2	112.8	22	28	17	63.7	-	-	267.5
CH100-60(XX)HP	100	16	48	32	25	132.00	118	1/4"	93.3	M8	15	30	28	M27x2.0	2	122.8	22	28	17	73.7	-	-	287.5
CH100-125(XX)HP	100	16	48	32	25	132.00	118	1/4"	93.3	M8	15	30	28	M27x2.0	2	187.8	22	28	17	138.7	-	-	417.5
CH100-150(XX)HP	100	16	48	32	25	132.00	118	1/4"	93.3	M8	15	30	28	M27x2.0	2	212.8	22	28	17	163.7	-	-	467.5
CH125-50(XX)HP	125	17	48	32	25	100.00	145	1/4"	109	M10	16	30	30	M27x2.0	5	114	22	28	16	49	-	-	272
CH125-150(XX)HP	125	17	48	32	25	100.00	145	1/4"	109	M10	16	30	30	M27x2.0	5	214	22	28	16	149	-	-	472
CH125-60(XX)HP	125	25	-	50.8	35	154.1	145	1/2"	109	M16 x 2	68	33	36	M40x2.0	4	124	32	-	10	83	83	20	313

NOTE :- XX = Ø10, Ø12, Ø14, Ø16, Ø20 AS PER CUSTOMER REQUIREMENT



Standard Cylinders Series T & TM (ISO 6431, VDMA 24562)

Piston dia 32 to 100 mm



Operating Conditions

Media	: Air (filtered 40µ & lubricated)
Temperature Range	: +5° to + 50°C
Pressure Range	: 0.5 to 10 bar
Leakage	: Bubble Tight

Mechanical Characteristic

Barrel	: Ø32, Ø40, Ø50, Ø63, Ø80, & Ø100 - Aluminium alloy
Piston Rod	: Carbon steel IS 5517-C35
End Caps	: Aluminium alloy
Seals	: Polyurethane (Viton for high temp. on request)



BASIC DIMENSIONS

SINGLE ENDED

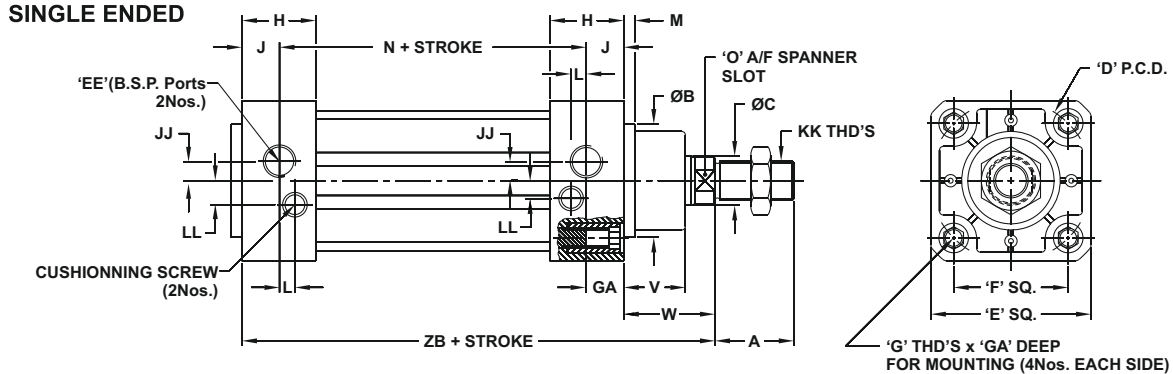

DOUBLE ENDED

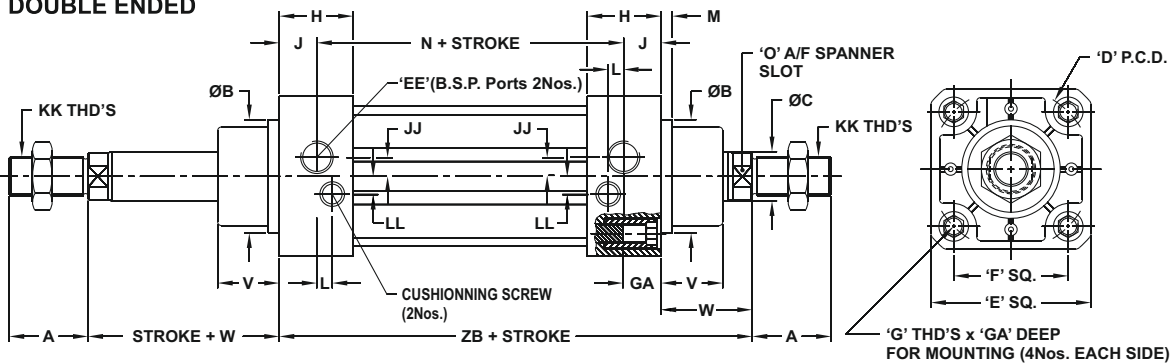

MODEL No.	PISTON DIA(mm)	A	ØB	ØC	D P.C.D.	E	EE B.S.P.	F	G	GA	H	J	JJ	KK	L	LL	M	N	O	V	W	ZB
T32	32	22	30	12	46	47	G1/8"	32.5	M6	16	27.5	12.5	5.5	M10 x 1.25	7	6	4	69	10	19	29	123
T40	40	24	35	16	53.7	53	G1/4"	38	M6	15	32	16	6	M12 x 1.25	7.5	8.5	4	73	13	21	33	138
T50	50	32	40	20	65.8	65	G1/4"	46.5	M8	15	31	15	7.5	M16 x 1.5	6.5	9.5	4	76	17	27	39	145
T63	63	32	45	20	80	75	G3/8"	56.5	M8	14	33	16.5	7.5	M16 x 1.5	7.5	11.5	4	88	17	27	40	161
T80	80	40	45	25	101.8	95	G3/8"	72	M10	16	33	16	8.5	M20 x 1.5	7.5	13.5	4	96	22	33	48	176
T100	100	40	55	25	126	115	G1/2"	89	M10	16	37	18	9.5	M20 x 1.5	8.5	13.5	4	102	22	36	53	191

- STANDARD STROKES STOCKED FOR QUICK DELIVERY : 25, 50, 80, 100, 125, 160, 200, 250 mm.
- FOR MAGNETIC ADD PREFIX 'TM' IN MODEL NO. (EXAMPLE : TM32, TM40, TM 50, TM 63, TM 80, TM 100)
- FOR DOUBLE ENDED & MAGNETIC ADD PREFIX 'TDM' IN MODEL NO. (EXAMPLE : TDM 32, TDM 40, TDM 50, TDM 63, TDM 80, TDM 100)
- ALLOWABLE STROKE TOLERANCE : 0 - 250 STK : $\begin{matrix} +0.5 \\ -0.0 \end{matrix}$, 251 - 1000 STK : $\begin{matrix} +1 \\ -0 \end{matrix}$, 1000 - 2000 STK : $\begin{matrix} +1.5 \\ -0.0 \end{matrix}$